

# **INTERNATIONAL LIFE SAVING**

## **SURF BOARD, SURF SKI AND SURF BOAT EQUIPMENT SPECIFICATIONS**

### **BACKGROUND**

Any competition equipment used by International Life Saving (ILS), ILS Member Federations, Clubs and members in ILS or IS sanctioned competition must be approved for use by ILS and listed in the current edition ILS Competition Manual.

Manufacturers or suppliers wishing to have their equipment accredited for use should contact ILS and adhere to the relevant ILS equipment specifications as published from time to time.

The following document outlines the specifications for the manufacture and supply of frontline Surf Board, Surf Ski and Surf Boat equipment.

Compliance with these specifications ensures that ILS, ILS Member Federations, Clubs and members ensures that such equipment is safe, of a high quality and is fit for sport operations.

The specifications listed in this document are the intellectual property of ILS and are to be strictly adhered to by all licensed manufacturers. ILS acknowledges Surf Life Saving Australia for the provision of these specifications to ILS for its competitions

### **PURPOSE OF SPECIFICATION**

These specifications refer to craft used in ILS competition and will be used by appointed ILS Officials to determine the eligibility, or otherwise, of craft.

Any competitor, or federation or club, who attempts to win a race by any other than honourable means, may be disqualified. This includes the use of craft not meeting the requirements of the appropriate ILS specifications.

Manufacturers have an obligation to ILS to ensure that all craft manufactured comply with the appropriate specifications.

Federations/Clubs/competitors have a responsibility to ensure craft remain with specification.

When a change in basic design is contemplated, manufacturers shall first seek the advice of ILS. An Advisor will be nominated by ILS to provide this advice under the authority of ILS.

### **VARIATION FROM SPECIFICATIONS**

Provision is allowed in ILS procedures for craft to be constructed outside the specifications – for the purpose of improvement of design, performance or material evaluation.

However, such permission can only be forthcoming from ILS in writing after a detailed submission in writing has been received. The applicant must not presume the application will have ILS approval.

Submissions must contain all relevant information and “drawings where applicable” or any other material requested by ILS in support of the application.

ILS may request development craft are constructed and tested at the applicants cost.

ILS permission to develop craft outside specification is no guarantee of final approval and such activity shall be at no expense to ILS.

Further, such craft shall not be permitted to be used in ILS competition or ILS sanctioned competition unless the ILS specifications have been amended to accommodate such changes.

## **DEFINITIONS**

Radius is the distance from the centre-point of a circle to the outer edge, as opposed to the diameter, which is the distance from edge to edge.

## TECHNICAL SPECIFICATIONS:

### 1. COMPOSITE SURF BOARD

- 1.1 Maximum length – 3.2m
- 1.2 Minimum Radii – Nose and Tail in plan view (see Figure 1) – 25mm
- 1.3 Minimum Radii – Leading edge Nose and trailing edge Tail in elevation view (see Figure 2) – 3mm.
- 1.4 Minimum Structural Weight – 7.6kg (includes one fin, plastic/rubber handles and knee/chest pads).
- 1.5 Minimum Width – not specified.
- 1.6 Only one fin is permitted and must have a minimum profile radius of 25mm at any point, minimum leading edge radius of 3mm and minimum trailing edge radius of 2mm.  
**NOTE:** Leading edge extends from the underside of the board to the lowest point of the fin.
- 1.7 The board may be constructed of foam sandwich core with a composite laminate skin or of thermoplastic construction solid or hollow with or without a soft foam surface.
- 1.8 Surf boards must contain a minimum flotation in the form of foam or other approved material to provide buoyancy of 20kg mass. If the buoyancy foam used in the manufacturing of the board absorbs water, a permanent sticker must be applied advising the user “if the outer protective layer is pierced the board will absorb water”.
- 1.9 Surf boards are to be of mono construction.
- 1.10 (When implemented) dated compliance labels are to be secured to the deck surface of all surf boards manufactured to ILS specifications warranting that the craft meets ILS specifications at the time of manufacture.
- 1.11 It is strongly recommended that all newly manufactured/approved surf boards be coloured with Hi Vis paint, resin or thermoplastic adhesive film from the tip of the nose and back from the end of the tail to a length of 100mm this can be part of the logo or design. Approved colours include Hi Vis green, red, yellow, pink or orange. Where the deck and hull (bottom and top) join an allowance of 10mm disconnect, is acceptable.
- 1.12 Exemptions apply to boards with nose and tail colours in excess of 100mm in green, red, orange, yellow or pink.
- 1.13 Surf board radius specifications:
  - a. Tail side view minimum radius 5mm.
  - b. Tail plan view minimum radius 25mm on both outside edges.
  - c. Nose plan view minimum radius 25 mm on both outside edges.
  - d. Nose side view minimum radius 3mm at tip of nose.

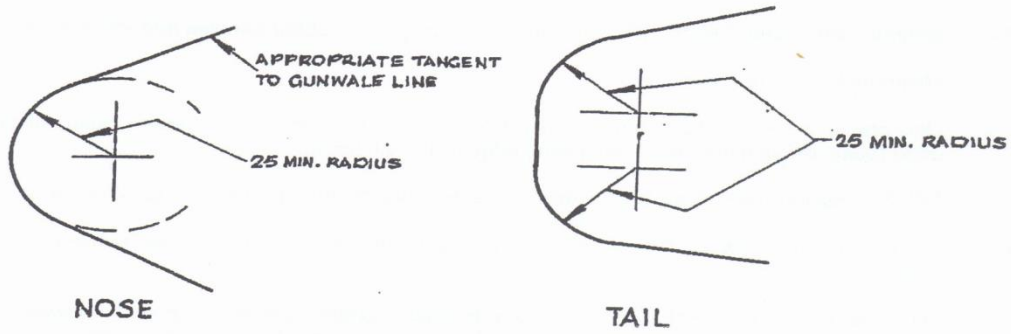

Figure 1 - PLAN



Figure 2 - ELEVATION

## 2. SINGLE SURF SKI

- 2.1 Maximum length 5.79 m (includes wave deflector – not including any rudder).
- 2.2 Minimum structural weight 18kg (excludes removable deflector, includes all rudders and mechanism, rudder pedals and cables, all flexible foot straps, adjustable foot blocks and mechanism, pedals and seat pads, fixed fins, hatch covers and starting handles).
- 2.3 Ski structural laminate construction must not contain more than 1 layer of 225 gm E glass CSM (except where reinforced patches are required) all other layers must consist of stitched fabric or woven fabric of E, S or R glass, carbon fibre or Aramid fibre.

Core materials maybe used provided they do not absorb water.

Gel coat must be a NPG Isophthalic ,NPG orthophthalic or Isophthalic with high UV protection.

**NOTE:** A Ski can lose weight after manufacture, if weight loss is less than 250gms the weight maybe replaced with permanent material provided the material is fixed to the craft e.g. Thermoset resin. Greater weight loss **MUST** be reported to ILS and the manufacture. The craft cannot be used within surf lifesaving until the weight is to the specification (18 kg).

- 2.4 Ski's to be of mono construction.
- 2.5 (When implemented) dated compliance labels are to be secured to the deck surface of all surf skis manufactured to ILS specifications warranting that the craft meets ILS specifications at the time of manufacture.
- 2.6 Minimum width shall be 480mm, measured at the widest point of the hull and exclude any rubbing strips, mouldings, additional protective mouldings or edge of rollover decks. If they are incorporated in the ski the measurement will be taken from the underside of the hull at the widest point excluding all rubbing strips, additional protective mouldings or rollover decks and shall have a minimum width of 480mm.
- 2.7 Minimum width at a point 400mm from the bow shall be 180mm.
- 2.8 Minimum width at a point 200mm from the bow shall be 75mm.
- 2.9 Where a built in deflector greater than 400mm in length is used, the minimum width 400mm from the bow shall be measured as detailed in Item 8.11
- 2.10 Where the deck and/or gunwale is raised in a manner which increases the width of the hull, the minimum width of 480mm is required to occur at a point on the underside of the hull on a line which represents the true line of the gunwale.
- 2.11 Reverse curve is permitted in the hull to provide greater lift and shall be built according to the following details.
- (i) Reverse curve is permitted in hull only between forward edge of foot wells and bow of ski
  - (ii) The maximum depth of the reverse curve shall be 20mm measured over 130mm span. Width of span to be measured from deck line when removable deflector or built-in deflector less than 400mm in length is used.
  - (iii) The maximum reverse curve width shall be measured at a point 400mm from the bow of the ski and will reduce to no reverse curve at a point to the front of the forward edge of foot wells.
  - (iv) When a built in deflector longer than 400mm is used the method following shall be used to measure the 180mm and 75mm minimum width of the hull. From the

underside of the ski any deflector length in excess of 400mm shall be disregarded and the measurement taken from the 400mm point.

An approved ILS template (see Figure 3) 180mm wide shall be placed against the underside of the ski, 400mm from the bow of the ski. Adjustable straight edges, fitted to the template, 130mm long shall be moved to touch the hull of the ski and check made to ensure reverse curve to such straight edges do not exceed 20mm each side.

- (v) No reverse curve in any direction is permitted in the hull between the front foot straps and the stern of the ski.

**NOTE:** When repairs or manufacture result in a reverse curve being created the ski should be filled and faired to remove the reverse curve.

## 2.12 Component Specifications

- (a) Deflectors (removable or built-in): Wave deflectors shall not be wider than maximum width of ski. Minimum edge radius shall be 3mm in elevation and in plan deflectors shall have a minimum radius of 25mm.
- (b) Rudders: Rudder blades shall be of composite material or other approved material. Rudders must have a minimum profile radius of 25mm, except at the hull, minimum leading edge radius of 3mm and minimum trailing edge radius of 2mm. Leading Edge extends from the underside of the hull to the lowest point of the rudder. Any fixed fin must also conform to this clause.
- (c) Rudder Mechanisms: There must be no projection of the rudder mechanism, e.g., balls, screws, nails, pins or rods etc which could cause injury or damage. A plastic cover shall protect all rudder cables made of stainless steel.
- (d) Footwells and seating wells shall be incorporated in the overall construction and be completely sealed from the hull.
- (e) Adjustable footblocks/straps may be used. Mechanism used in the adjustment must be approved and have no projections or sharp edges that can cause injury.
- (f) All foot straps MUST incorporate an approved centre release system.
- (g) All ventures protruding from the hull must have a minimum of 1.5mm radius on all exposed edges and be designed so no leading edge can cause injury due to wear through use. They must be constructed of plastic, rubber or composite. The use of metal ventures is not permitted.

- 2.13 Flotation: Single skis shall contain a minimum flotation in the form of foam or other approved material to achieve 30kg of positive buoyancy.

Flotation foam must not absorb water. If polystyrene is used the surface MUST be sealed.

- 2.14 It is strongly recommended that all newly manufactured/approved surf skis be coloured with Hi Vis paint, resin or thermoplastic adhesive film from the tip of the nose and back from the end of the tail to a length of 100mm this can be part of the logo or design. Approved colours include Hi Vis green, red, yellow, pink or orange. Where the deck and hull (bottom and top) join an allowance of 10mm disconnect, is acceptable.

- 2.15 Exemptions apply to Single Surf Skis with nose and tail colours in excess of 100mm in green, red, pink, yellow, or orange.

- 2.16 Design: Minimum measurements along the hull from a flat horizontal surface require are as follows:

- (a) 75mm at stern to underside, which will be the general continued curvature line of the hull.

- (b) 300mm at bow along true line of gunwale. (Deflectors are not considered to be a part of a true line of the gunwale and should not be included in the measurement).
- (c) At 600mm in from stern, a clearance of 50mm.
- (d) At 100mm in from bow, a clearance of 200mm.
- (e) At 400mm in from bow, a clearance of 75mm.
- (f) A single ski less than the maximum length of 5.79 metres must still comply to the measurements from bow and stern – for the curvature check.

**For measuring:** The ski must sit on ILS's standard jig (see Figure 4) and touch or clear all jig measurements, keeping within the overall length. For skis less than the minimum length the jig must be adjusted to the length of the ski.

There must be no reverse curvature of the bottom of the ski from the bow to the line of the ILS's standard jig.

**NOTE:** For details of procedures of measurement refer to the appropriate Bulletins issued by Australian Council on Scrutineering of Surf Craft.

- 2.17 As a safety precaution, minimum profile of hull/deck at tail and bow (where removable deflector is used) of skis in either plan or side elevation shall be 25mm. Minimum radii in other directions to be 4mm. Further minimum radii of V bow to be 4mm.
- 2.18 Projection of the overlapping deck past the hull at tail (and bow) to not exceed 5mm.
- 2.19 If a deck is less than 25mm deep at the join the 25mm radius must extend to 25mm depth minimum.
- 2.20 Ski Paddles. Currently no specification for paddles exists. However, all paddles must be free of sharp or jagged edges (which may cause injury). Metal tipped paddles are NOT permitted to be used. Paddles with adjustable handles must have tape covering the joining mechanism.
- 2.21 Carrying handles may be attached to the skis such handles are not to cause injury and are approved by scrutineers.

Figure 3 - Detail of approved ILS Jig for measuring reverse curve of Ski  
(NOT TO SCALE)

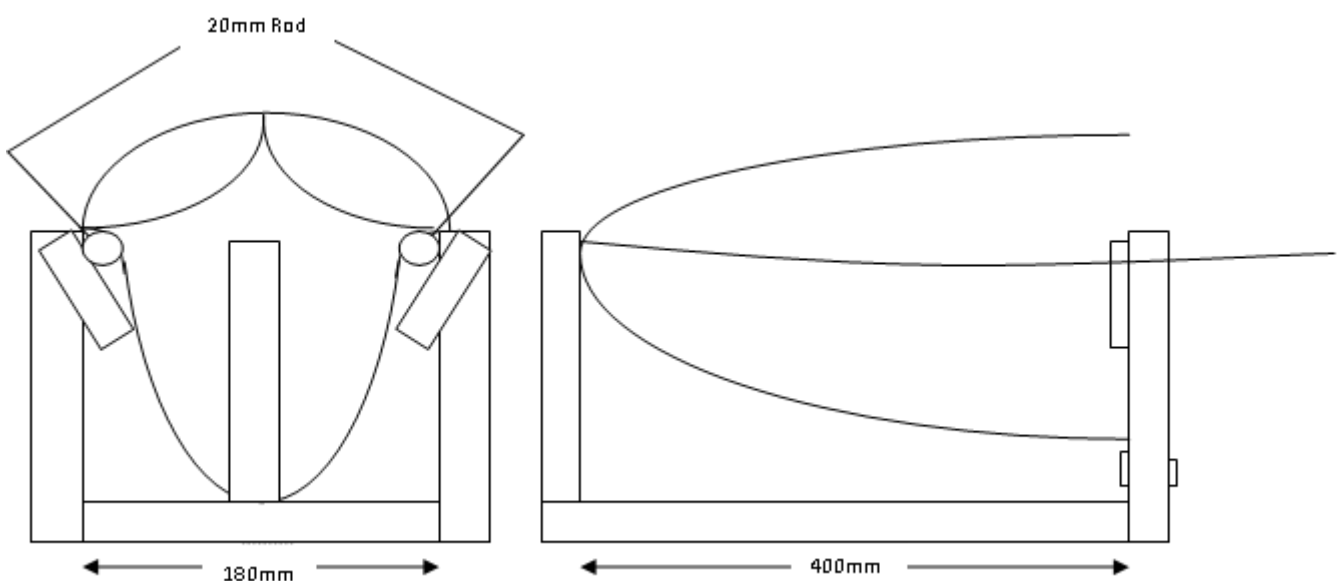
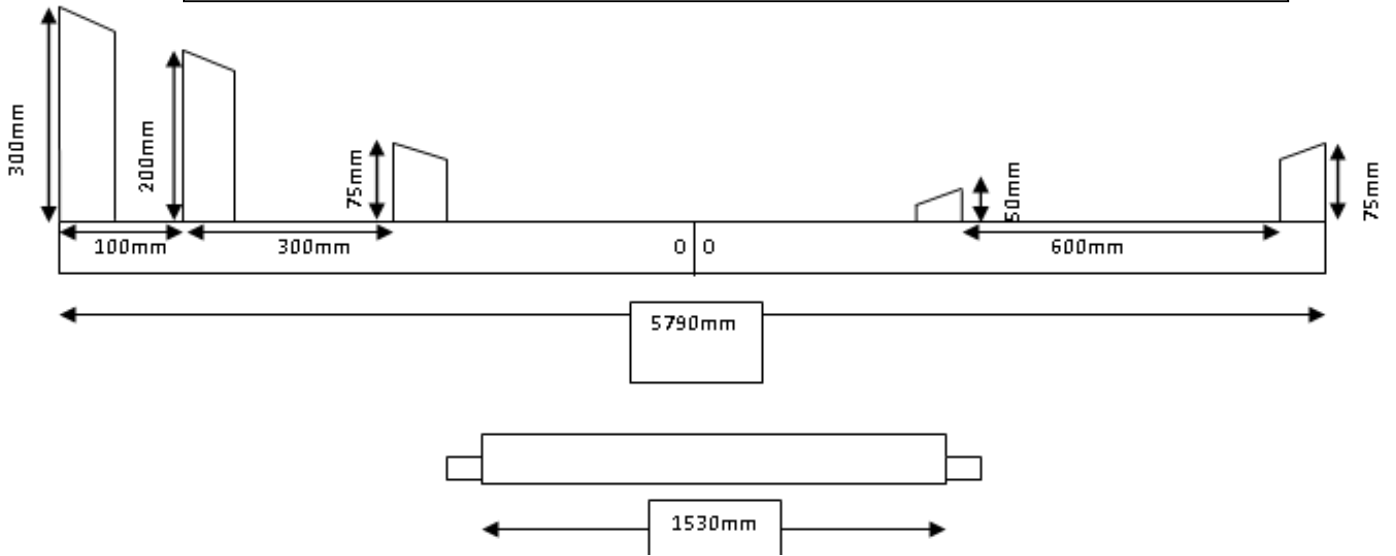
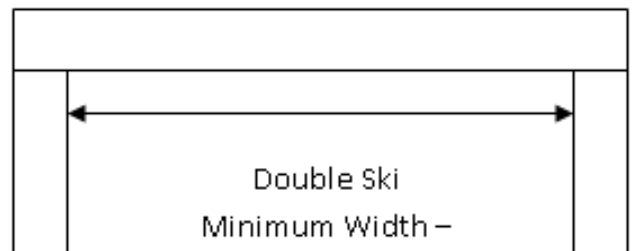
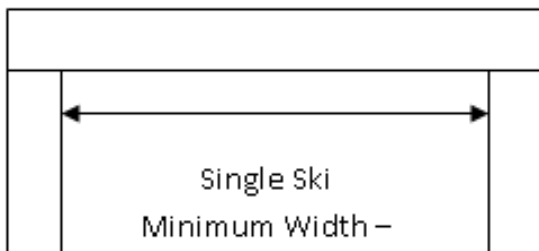
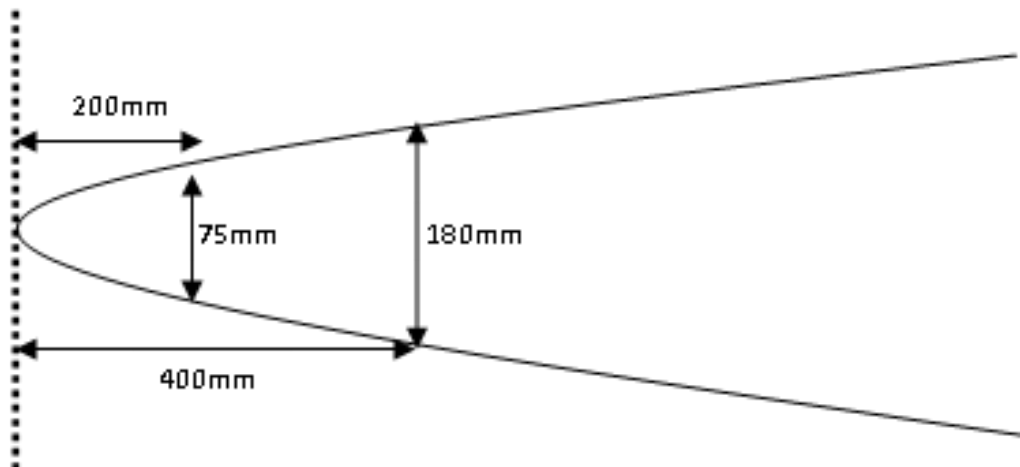

Figure 4 - Single Ski Jig  
(NOT TO SCALE)



Add 1530mm spacer into centre of single jig to expand for Double Ski Jig.  
Total length of Double Ski Jig should be 7320mm





**2.22** Communication and Video Devices on Surf Board and Skis:

- a) The use of communication devices is **NOT** permitted by competitors from commencement to completion of a race.
- b) The use of one video camera is permitted on surf boards and surf skis provided it is installed on a mounting device and toggle strap supplied or recommended by the manufacturer of the device.
- c) Installation on 3.2m Racing Surf boards shall be approximately midway between the hand grips closest to the nose and the nose of the craft.
- d) Installation on single and double skis shall be in front of the foot well.
- e) The weight of any plugs permanently installed into the craft to attach the video camera shall be included in the overall weight of the craft.
- f) The weight of other (non-permanently installed) mounts and camera are **NOT** to be included in the overall weight of the craft.

### **3. SURF BOATS**

#### **3.1 General**

- 3.1.1 Boat manufacturers commencing construction of composite foam sandwich boats for the first time shall submit a test panel as directed by the ILS of the proposed layup, with full details to the appointed ILS Adviser.
- 3.1.2 Any proposed changes or alternatives to approved layups, stiffening or construction shall be submitted prior to construction, along with supporting professional engineering calculations and advice, for the consideration and approval of ILS. As a minimum requirement, the layups shall be at least as strong (e.g. equal or greater reinforcement fabric weight and improved fibre orientation) as the presently approved layups in the Specification.
- 3.1.3 All components and items listed in HULL CONSTRUCTION (Clause 6.3.) shall be fitted to the boat unless described as advisory or where an otherwise ILS approved alternative is allowed.

#### **3.2 Dimensions**

- 3.2.1 Length Overall – minimum 6.86m to a maximum 7.925m (not including the sweep outrigger).
- 3.2.2 Beam – Minimum of 1.62m between projections of outside hull at top of gunwale, measured at widest midship section near to Nos. 2 or 3 thwart; see also Clause 4.2.4.
- 3.2.3 Moulded depth – Minimum of 558mm from top of gunwale to lowest part of outside hull at keel, measured at the same section as the beam measurement.
- 3.2.4 Hull reverse curvature – Any reverse curvature of the hull, between the stern and a point 3.04m from the bow, shall be limited to a maximum of 13mm, measured between gunwale and keel. Where the gunwale has been moulded, or where the outside hull at top of the gunwale is otherwise hard to measure, the reverse curvature may be measured by placing a straight edge batten over the hull with the top end of the straight edge within 5mm of the gunwale. A projection of the straight edge to the top of the gunwale must also comply with minimum beam measurement requirements of Clause 4.2.3.
- 3.2.5 Longitudinal Hull Profile – Minimum hull depths and the minimum profile, relative to the baseline at a maximum of 57mm from the hull at midships, shall be in accordance with the dimensions given in Figure 1. The gunwale and keel centre line at hull profiles shall each maintain a smooth and continuous curve.

#### **3.3 Hull Construction**

- 3.3.1 Construction Materials – wherever the words ‘suitable or approved timber’ are mentioned they shall refer only to one of the species allowed in the Specification and shall be suitable for the particular purpose. Similarly, for GRP (E-Glass fibre Reinforced Plastic) and closed-cell foam core materials the type and minimum weights/densities shall be as specified or otherwise approved by the ILS. Adhesives used shall be either Urea, Resorcinol, Melamine, Methacrylate (Plexus, Weldon etc.) or Epoxy and shall be a gap filling, marine grade, suitable for the particular purpose. Resins used shall be marine grade, suitable for the

particular purpose and the resin to glass fibre ratio shall typically be 2:1 by weight for CSM (Chopped Strand Mat) and CFM (Continuous Filament Mat for vacuum resin infusion) and 1:1 (hand-layup) or 0.7:1 (vacuum resin infusion) by weight for E-glass stitched non-crimp non-woven reinforcement fabrics. That is, for optimum strength the percentage of glass fibre content shall be matched to the reinforcement style in recognition of best practice. The use of resin only, without fibre reinforcement, to build up structure or to add hull weight is not permitted.

- 3.3.2 Fastenings and Fittings – The fastenings shall be as specified, or of marine grade composition, suitable for the particular application from the following metals: ASTM 316 stainless steel, monel metal, silicone bronze, aluminium bronze or copper. The use of brass, steel or plated steel fasteners is not permitted, with exception of brass in electrical circuit fastenings only. Brass or steel shall not be used for any fittings unless specifically allowed in the Specification. All fittings and fastenings shall be installed ensuring that there are no dangerous protruding, sharp edges or screw threads.

### 3.3.3 Foam Sandwich Hull

3.3.3.1 Core Material – Core material shall be an approved PVC or SAN foam (presently approved products are Klegecell, Airex, Divinycell and CoreCell). The minimum manufacturer's nominal sheet density shall be 70kg/m<sup>3</sup>. The minimum nominal thickness shall be 12mm in hulls and generally 10mm in decks (6mm in fore and aft cover decks and bulkheads).

3.3.3.2 Skin material – The type of fibre in the reinforcement fabrics used shall be conventional E-glass and resin in the laminate must be marine grade polyester or vinylester containing styrene and suitable for the purpose. Resin used in the vacuum infusion process shall be specifically formulated for this process.

3.3.3.3 Basic hull shell layup – the outside GRP sandwich skin laminate shall have a minimum of 675g/m<sup>2</sup> dry fibre. The layup shall include a minimum 225g/m<sup>2</sup> CSM (Chopped Strand Mat) as a tie/skin coat behind the gelcoat. The inner GRP sandwich skin laminate shall have a minimum of 450g/m<sup>2</sup> of dry fibre. Basic deck shell layup shall comprise a minimum of CSM – 225g/m<sup>2</sup> either side of 10mm foam core.

3.3.3.4 Multi-Layers of Woven Cloth – Should multi-layers of woven reinforcement be used anywhere in the construction of the hull or fittings, a layer of CSM (e.g. 225g/m<sup>2</sup>) shall be placed between each layer of cloth. This provision does not apply if the vacuum infusion process is used in the layup of the hull or deck shells.

3.3.3.5 Connection of Layup Skins – The inner and outer skins shall be solidly connected or joined at the gunwale by excluding the foam core or replacing it with a suitable high-density core. The core material shall be continuous from gunwale to gunwale, or shall be divided at the centre line of keel with skins fixed to, or integral with, the full internal keel in one of the following ways, or otherwise as only approved by ILS:

- (a) (i) The foam core shall cease 50mm from each side of centreline;

- (ii) The edge of the foam next to centre line shall be chamfered on its inner edge at a minimum taper of 1:1;
    - (iii) The inside skin shall join the outside skin at the bottom of the chamfered edge and overlap the centre line a minimum of 50mm;
    - (iv) The internal keel shall be bonded to the lapped skins using epoxy adhesive, OR,
  - (b)
    - (i) A timber spacer, 50mm x 12mm section shall be shaped and laid full length to fit outside skin along the keel line, and effectively glued using epoxy adhesive;
    - (ii) The foam core shall be laid hard up to the edge of the timber spacer and the inside skin laid over foam and the timber spacer;
    - (iii) The internal keel shall be glued to the inside skin over the top of the keel line timber spacer using epoxy adhesive; OR,
  - (c)
    - (i) The internal keel shall be effectively glued to the outside skin using an epoxy adhesive;
    - (ii) The foam core shall be laid hard up to the internal keel on each side;
    - (iii) The inside skin shall be laid over the foam core and internal keel in a continuous run.
- 3.3.4 Single Skin Glass Reinforced Plastic (GRP) Hull. Refer to SLSA Oct 10, 2002 Specification. Builders of single-skin FRP boats use SLSA Oct 10, 2002 rule.
- 3.3.5 Timber Sandwich Hull. Refer to SLSA Oct 10, 2002 Specification. Builders of timber/timber-sandwich boats use SLSA Oct 10, 2002 rule.
- 3.3.6 Scantlings, Stiffening and Strengthening – All “timbers”, including stringers, risers and gunwales, where used, shall be full length, straight grained, approved timber varieties. If stringers, risers and gunwales cannot be fitted in one length, the use of scarf joints shall be acceptable with a full taper ratio of minimum 12:1. Where specifically allowed in the Specification a ILS approved foam cored GRP construction may be used in lieu of timber.
- 3.3.7 Structural and Scantling Sizes – All sizes quoted for timber, other material scantlings and structural components shall be the minimum finished sizes. Extreme or unnecessary dressing, scalloping, bevelling or shaping of timbers shall not be permitted. Similar restrictions shall apply to specified sandwich construction alternatives.
- 3.3.8 Inner gunwale – The inner gunwale shall be 44mm x 22mm Silver Ash, Mountain Ash, Yellowwood or White ash efficiently glued to the hull. The dimensions shall be maintained continuously for the length of the boat and shall not be bevelled or scalloped to attach fittings.
- 3.3.9 Outer Gunwale – The outer gunwale (gunwale mould) shall be 44mm x 22mm Silver Ash, Mountain Ash, Yellowwood or White Ash screwed and glued to the hull and inner gunwale. The depth shall be maintained continuously for the total length of the boat and shall not be bevelled to attach fittings. Some shaping of the thickness is permitted forward of the splashboard. As appropriate, any end grain hull veneers or soft core material shall be sealed off, for example with a 3mm cover board or a suitable high-density core material. The gunwale unit shall not be weakened in the fitting of the rowlock bosses, etc.

- 3.3.10 Gunwale Strengthening – Inner gunwales shall be strengthened, underneath or adjacent to rowlock fittings, with 44mm x 19mm timber of the same species as the inner gunwale and shall extend full length between adjacent thwart knees; they may be tapered from the rowlock fitting to the knees or to a minimum of 300mm if the knees are not fitted. Alternatively, equivalent strengthening at the bow and stroke rowlocks may be fitted only on the outside of outer gunwale or may be incorporated in outrigger construction.
- 3.3.11 Foam Sandwich Gunwales – Alternatively, the gunwales may be of an approved foam sandwich construction but maintaining the dimensions and profile, and excluding and bevelling or shaping, as per timber gunwales. The following are presently approved layups:
- 3.3.11.1 Construction No 1 – The inner and outer gunwale shall each be a minimum of 44mm x 20mm approved foam with a minimum nominal density of 130kg/m<sup>3</sup>. The GRP skin layup shall be a minimum of: - 1000g/m<sup>2</sup> E-glass fabric or unidirectional rovings
- 3.3.11.2 Construction No 2 – The total gunwale is 44mm deep x 50mm wide approved foam with a minimum nominal density of 130kg/m<sup>3</sup>. The GRP skin layup is: - 2 layers of min. 668g/m<sup>2</sup> triaxial reinforcement fabric
- 3.3.11.3 Construction No 3 – The inner and outer gunwales are each 55mm deep x 25mm wide approved foam with a minimum density of 130kg/m<sup>3</sup>. The GRP skin layup is:
- |                       |                                  |
|-----------------------|----------------------------------|
| Unidirectional Roving | 500g/m <sup>2</sup> (fore & aft) |
| 2 layers Woven Fabric | 330g/m <sup>2</sup> each         |
- 3.3.12 Stringers and Seat Risers – Stringers and seat risers, when used shall be 32mm x 19mm approved timber (extending from stem to stern) glued to contacting surfaces. Timers approved are: Silver Ash, Yellowwood, Spruce, Oregon, Alpine Ash, Coachwood, Celery-Top Pine, Hoop Pine, Huon Pine, Myrtle Beech, Queensland Maple, select Spotted Gum. A foam core with GRP skin of the same layup as the hull may be used in lieu of timber in stringers and seat risers.
- 3.3.13 Stringers in Single Skin GRP Hulls – Hulls of solid GRP construction shall have a minimum of two full-length stringers (stiffeners). If a buoyancy insert or tanking is used, its construction may be incorporated with the hull stringers which shall maintain continuity end to end.
- 3.3.14 Internal Keel – A full length internal keel shall be fitted using Oregon, Spruce, Celery-Top Pine or Huon Pine and the unshaped size shall be 98mm x 31mm; if Silver Ash, Mountain Ash, Alpine Ash or White Ash the unshaped size shall be 76mm x 31mm; or if a foam box section is used the unshaped core size shall be 98mm x 36mm which shall be fully encased in a GRP skin. An alternative approved construction is, when using full length buoyancy tank inserts, the longitudinal bulkhead verticals are considered to replace the role of the box section internal keel, providing: (a) the verticals are fully glassed and within 180mm of the centre line; (b) a minimum of 75mm of each side of each vertical is additionally glassed with min. 300g/m<sup>2</sup> reinforcement fabric each side and adequately glassed to the hull; (c) the reinforcement component in the normal lapped hull skin layup between the verticals is increased by a minimum of 40%; and (d) the lapped hull layup must be adequate to support the external false keel and connections.

- 3.3.15 External False Keel – A full length external keel shall be glued and/or screwed to the internal keel over the lapped hull layup using 38mm x 19mm Silver Ash, Yellowwood or Alpine Ash. The false keel may be shaped from 38mm down to 19mm at the keel rubbing band and the depth may be evenly tapered from 19mm to 6mm over the aft 1.8m. The keel rubbing band shall not include brass in its composition. Suitable plastic materials are recommended and metallic bands are generally discouraged for reasons of crew safety.
- 3.3.16 Deep False Keel – Variations to the above configuration may be permitted if they comply with the following guidelines. The false keel shall be:
- (a) of minimum length 2m;
  - (b) placed, as a minimum, between No 2 thwart and the quarter bar;
  - (c) of maximum depth 75mm;
  - (d) of minimum single side elevation area 0.10m<sup>2</sup>, i.e., greater than a basic 75mm x 2.67m triangular shape plus an allowance for the concave curvature next to the hull or equivalent area variations;
  - (e) suitably tapered at each end;
  - (f) fitted with an approved rubbing band extending as a minimum from the bow to the bottom of the stern end of the false keel. The rubbing band is optional from the stern end of the false keel to the stern; and
  - (g) material may be GRP of equivalent layup as hull.
- 3.3.17 Stem – The stem shall be reinforced internally with either:
- (a) a suitable timber insert shaped from 25mm x 36mm section effectively glued to inside of hull: OR,
  - (b) a minimum of two layers of 15mm foam interleaved with two layers of reinforcement fabric similar to hull layup and extending a minimum of 200mm either side; OR,
  - (c) the GRP hull layup overlapping at least 200mm either side.
- 3.3.18 Thwarts – Thwarts shall be fitted using 178mm x 22mm approved timber, suitably glued and/or screwed or fibreglassed at the seat risers or support blocks. Alternatively, they shall be 178mm x 20mm approved foam and sheathed with same layup as the hull.
- 3.3.19 Thwart Stanchions – The thwarts shall have stanchions which shall be:
- (a) of approved timber insert of 125mm x 22mm section effectively glued and or screwed and fastened with shoulder moulds to thwarts and keel to function as both a tie down and support to the thwart. The stanchions may be shaped, provided a minimum of 75% of its original cross-sectional shape is retained; OR,
  - (b) of approved foam material with the same layup as hull and effectively glassed to thwarts and keel. The foam stanchion may be constructed as part of a sealed box designed to support the thwart; OR,
  - (c) alternatively, if the stanchions above are not used the thwarts shall be constructed as an inverted U and be of same thickness and construction as the thwart, with the depth of the downward flanges to be a minimum of 200mm where the flange contacts the inner hull (see figure 2).
- 3.3.20 Thwart Knees – Thwarts shall be fitted with knees by one of the following methods:
- (a) Each thwart shall have four timber knees, blocked and glued to the hull, with three fastenings to the thwart and one through the gunwale. The knees shall be grown Tea-tree, plywood or steamed laminates and of

22mm minimum thickness. Copper fastenings (boat nail and roove/burr) through the gunwale may be replaced with 10 gauge screws of approved material, which shall penetrate the outer gunwale a minimum of 10mm; OR,

- (b) Each thwart shall have central single knees at each end of all thwarts of the above timber or similar sandwich construction as the hull and shall extend from the thwart to near the top of the inner gunwale. The knees shall be adequately glassed to the inner gunwale, inside hull and the thwart with additional reinforcement extending the full width of the thwarts; OR,
- (c) Each thwart shall have a sandwich foam stiffener of the same width as the thwart at each end. The stiffener shall be of the same thickness as the hull and extend from the thwart to near the top of the inner gunwale, and shall be adequately glassed to the inner gunwale, inside hull and the thwart (see Figure 3).

3.3.21 Extra Thwart – An extra thwart shall be fitted between the quarter bar and the stroke thwart by one of the following methods:

- (a) of 75mm x 19mm approved timber, strengthened on underside by 38mm x 19mm timber on edge and tapering to the hull or by a 62mm x 19mm stanchion, and shall be fastened to hull with 2 knees similar to thwart knees; OR,
- (b) of 62mm x 20mm approved foam and strengthened on underside with 62mm x 20mm approved foam on edge, both with same layup as the outer hull; OR,
- (c) an approved sealed chamber shaped to the hull may be used with approved knees fastened to the hull as in 6.3.20.

3.3.22 Buoyancy tank insert – A suitable buoyancy tank insert may be moulded and/or fitted inside the hull, also contributing to hull strength, and may incorporate part of the function of the thwarts and stanchions. All such inserts and “liners” generally shall be bonded to the inner surface of the hull shell with similar materials so as to form a structural connection in at least three locations, two of which are to be the gunwales. The following modifications may then be incorporated.

3.3.22.1 Buoyancy Tank Insert Knees – In sandwich construction only, the “thwart” knees/stiffeners may be deleted if complying with all the following conditions:

- (a) a suitable buoyancy tank insert is fitted to the inside hull;
- (b) the insert runs continuously the length of the hull and contributes to boat strength;
- (c) the full thickness sandwich construction hull runs through and between the inner and outer gunwales; and,
- (d) there is suitable reinforcement doubling at the insert/hull interface at the normal thwart/riser height and running the full length.
- (e) Note that knees/stiffeners are still required in all other types of construction.

3.3.22.2 Insert Tank Thwarts – in boats fitted with full length buoyancy tank inserts, a minimum of three thwarts including the bow shall be fitted. The thwarts shall be of the above specified size and shall be incorporated into insert so that full strength is maintained across the boat, gunwale to gunwale.

- 3.3.22.3 Hull Decking – The decking shall be moulded and securely screwed/glued to, and supported by, the gunwales and at least two deck beams of 75mm x 22mm timber or equivalent GRP/foam sandwich shall be securely connected to the gunwales. The decking shall be constructed by one of the following methods:
- (a) 6mm minimum core GRP foam sandwich; OR,
  - (b) 5mm ply covered with 3mm timber veneer; OR
  - (c) 2 x 3mm moulded timber veneers to finish not less than 6mm thickness
- 3.3.23 Buoyancy – As a safety provision the boat shall remain buoyant in the damaged condition and/or with inspection hatches missing or open. Buoyancy shall be provided as follows:
- 3.3.23.1 Buoyancy – Full foam Sandwich Hull Construction additional buoyancy not required.
- 3.3.23.2 Buoyancy-Solid GRP Hull Construction – Two units to a total minimum of 0.4m<sup>3</sup> of polystyrene foam, or similar material, evenly distributed fore and aft to ensure the boat will float when damaged and full of water. The additional foam shall be used unless demonstrated that sufficient buoyancy exists.
- 3.3.24 Coaming – A coaming shall be provided aft of the forward decking using 10mm timber, moulded or laminated in one piece, to stand 75mm above decking at the centre, or in two pieces fixed to three knees. Alternatively, the coaming may be made of GRP or foam sandwich of same layup and thickness as the hull.
- 3.3.25 Tuck – The tuck stern shall be of same materials used in hull skin and shall be additionally reinforced with a minimum 12mm timber or foam backing or core. Timber may be used as the core material for a sandwich tuck, or as backing for an effectively reinforced solid GRP tuck.
- 3.3.26 Quarter Knees to Tuck – Two quarter knees shall be fitted using 22mm sided Tea-tree or laminated or moulded plywood. Alternatively, an approved GRP lamination may be used.
- 3.3.27 Breast Hooks – Breast hooks knees shall be fitted using 22mm sided Tea-tree or moulded plywood, suitable timber or approved GRP or foam sandwich construction moulded to shape of hull.
- 3.3.28 Sweep Outrigger – The sweep outrigger shall be a minimum 150mm x 50mm Silver Ash, Mountain Ash, Yellowwood or Blue Gum securely fixed and glued to deck beams and fastened to the tuck with a 38mm sided knee or metal bracket. Alternatively, the sweep outrigger may be constructed with 150mm x 60mm approved foam, with a minimum density of 130kg/m<sup>3</sup>, sheathed with a minimum of 1000g/m<sup>2</sup> of dry reinforcement and glued or glassed to the tuck and deck structure. The outrigger may be tapered down from the tuck to the aft bulkhead.
- 3.3.29 Quarter Bar – The quarter bar shall be shaped from a suitable timber minimum 63mm x 25mm and bolted to the gunwale with maximum 6mm stainless steel bolts; or, glued using epoxy adhesive and fastened each end with 75mm x 10 gauge stainless, monel metal or silicone bronze screws.



Alternatively, the quarter bar may be constructed with 60mm a 60mm approved foam, sheathed with a minimum of 1000g/m<sup>2</sup> of dry reinforcement and glued or glassed to gunwales.

- 3.3.30 Foot-stretchers – Foot-stretchers shall be a minimum of 10mm marine ply laminate; or, 20mm approved foam, sheathed with a minimum of 225g/m<sup>2</sup> of dry reinforcement (e.g. CSM – 225g/m<sup>2</sup>) ; or, approved equivalent GRP construction. These alternatives may be incorporated into the buoyancy tank insert.
- 3.3.31 Keel Band – The keel band shall be 19mm, marine grade stainless or approved non-ferrous or synthetic material. Note, this item needs regular inspection to ensure there are no damaged or sharp edges.
- 3.3.32 Rowlock Fittings.
- 3.3.32.1 Metal rowlock Fittings – The four rowlock fittings shall be fabricated from marine grade stainless steel or monel metal; or cast from marine grade phosphor bronze or similar. The fittings shall fit over the top of the gunwale or approved outrigger gunwale construction and designed so that rowlocks and oars are in the correct position of r rowing. All sharp edges shall be eliminated and corners to top and bottom plates shall have a minimum 10mm radius. Fastening shall be kept to a minimum to avoid weakening of the gunwale. Fabricated fittings shall include a full tubular section for housing the rowlock shaft and the inside of this shank tube shall not extend more than 10mm from a longitudinal line parallel to the widest line of the outer gunwale. Any rowlock fitting may be outriggered to a maximum of this widest line and is called an “outrigger rowlock fitting”.
- 3.3.32.2 Moulded GRP Rowlock Fittings – The rowlock fittings may be incorporated into GRP gunwale construction. The dimensions and restrictions shall be as for the metal fittings. The reinforcement fabric layup of the approved GRP gunwale shall be increased a minimum of 200% at the fitting, and a suitable synthetic or metal shank tube incorporated into the construction. Note: this fitting may not be as strong as the metal type.
- 3.3.33 Outrigger Rowlock Fittings – An outriggered rowlock fitting is defined as one where the inside of the shank tube is more than 10mm from the normal outside line of the top edge of the outer gunwale. Outriggered fittings must be additionally protected for safety by a method approved by ILS. Approved methods are as follows:
- (a) Cover Plates. The top and bottom plates of the rowlock fittings shall be fully enclosed with an approved metal cover ensuring that there are no protruding or sharp edges and the fitting shall have a minimum taper of 1:1, fore and aft (see Figure 4). This enclosed fitting only, may also be used in combination with the outer gunwale outriggered with the approved timber or GRP foam sandwich and which shall extend fore and aft with a minimum taper of 1:1.
- (b) Protective Wedges. Other types of outrigger fittings, if not fully enclosed and/or not tapered correctly, shall be protected, fore and aft, by timber wedges of species approved for gunwales. The wedges shall have a minimum taper of 3:1, and shall extend from the outer gunwale to the

inside edge of the shank tube as a minimum, or to the outside edge of the fitting as a maximum. The depth of the wedges shall taper from the full fitting depth, at the fitting, down to the full depth of the gunwale, at the gunwale. The wedges shall be suitably rounded, adequately glued and screwed to the gunwale gaps minimized in the fitting and not exceeding 10mm (see Figure 5).

- 3.3.34 Rowlocks – The rowlocks shall have sufficient spring to allow the oars to be released should they become fouled under the boat. The rowlocks shall also be designed so the oars will slip out when pulled inboard past the leather or synthetic sleeve. The rowlock shank shall not be greater than 16mm diameter, shall not protrude more than 50mm below the rowlock fitting and shall have a hole at the heel for a rowlock retaining pin. The retaining pin shall be manufactured from stainless steel or monel metal and be ring shaped without sharp or protruding ends to prevent injury.
- 3.3.35 Sweep Rowlock – The rowlock shall be manufactured from stainless steel, monel metal or galvanized steel, may be rounded or goose-necked and bolted through the sweep outrigger rowlock fitting of similar material for rowlock fitting. Nyloc type nuts or a nut with a ring shaped pin shall be used to prevent release and injury.
- 3.3.36 Bungs – Drain holes in the hull and/or stern shall have the bungs attached to the boat by nylon cord or non-ferrous chain and screw fittings.
- 3.3.37 Oars – There is no specific Specification for surf boat oars. However, for safety the blade shall have a minimum 6mm thickness with no sharp corners at the edges.
- 3.3.38 Rescue Tube – An ILS approved rescue tube shall be fixed to topside of the bow thwart decking or tank top by velcro straps (for quick release).
- 3.3.39 Optional Equipment – Additional equipment may be fitted or carried on the boat and includes pumps additional GRP seats, ILS approved sliding seats, approved signal plate, signal flags, stainless steel boat or raft knife and buckets. Specific requirements are as follows.
  - 3.3.39.1 Pumps – A maximum of two manual or battery operated pumps of unrestricted capacity may be fitted ensuring that associated piping and fixtures cannot cause injury.
  - 3.3.39.2 Batteries – The batteries used shall be restricted to the fully sealed type and shall be securely attached to the boat in a battery housing of suitable shape and material. The battery housing does not need to be fully enclosed or waterproof; but if the battery is contained in a box, breathing holes shall be provided to dissipate any dangerous gases. Care should be taken when charging the sealed batteries which should be done out of the boat and only using chargers suitable for this type of battery. NOTE: ORDINARY CAR BATTERIES SHALL NOT BE USED. Associated switching and wiring fitted for pumps and batteries shall have no sharp or protruding parts, edges, screws, etc, by design and/or location which could cause injury.
  - 3.3.39.3 GRP Seats – GRP seat shall be suitably fastened to thwarts or Buoyancy Tank inserts ensuring that they shall be readily removed

for scrutineering and ensuring that there are no gaps, sharp edges or corners, etc, that could cause injury. If GRP seats are incorporated permanently, or are part of the buoyancy tank insert moulding and/or the thwart, then a minimum weight allowance of 10kg for the seats shall be added to the minimum allowed weight of the 180kg (refer section 7.3).

- 3.3.39.4 Sliding seats – Only sliding seats approved by ILS may be used in normal ILS competition. Special events, etc, may specifically allow other types. Currently the only ILS approved sliding seat is the Ferrett (South Australia) design and manufacture.
- 3.3.39.5 Weight - The bare weight of the finished craft shall have a minimum weight of 180 kg, with a maximum weight of 190 kg. Final weight excludes all equipment and seats. Finished craft must be signed off by the builder and the purchaser or their designated official
- 3.3.39.6 Racing weight- The racing weight of the surf boat shall have a minimum weight of 200 kg including seats, pumps and foot blocks. Excludes rowlocks, oars, batteries and any other additions. This section **MUST** be read in conjunction with 4.3. 39.5 (bare weight of hull to have a minimum weight of 180 kg).

#### **3.4. Communication and Video Devices on Surf Boats:**

- a) The use of communication devices is **NOT** permitted by competitors (either attached to a craft or to their person) from commencement to completion of a race in Championship competition.  
  
However, Surf Boat Sweep Coach Mentors, Assessors and Level 3 Coaches may, with the support of the appointed Boat Panel, make application to the Referee to utilize electronic communication devices at non-championship competitions to further mentor boat sweeps to gain competency in surf conditions, provided that such mentoring does not extend to "competing unfairly".
- b) With the exception of Boat Sweeps the use of a video camera attached to any part of a competitor is not permitted from the commencement of, to the completion of a race.
- c) The use of video cameras on Surf Boats is permitted provided they are installed on a mounting device and toggle strap supplied or recommended by the manufacturer of the device.
- d) Installation shall be permitted on the splash board (front deck), on the tank opposite the stroke's seat (No.4) and rear deck.
- e) The weight of any plugs permanently installed into the boat to attach the video camera shall be included in the overall "bare weight" of the boat.(d) The weight of other (non-permanently installed) mounts and camera are not to be included in the overall "racing weight" of the craft.
- f) A Surf Boat Sweep (only) is also permitted to have a video camera on a helmet, worn by them, provided that the camera is installed on a mounting device and toggle strap supplied or recommended by the manufacturer of the device.

### **3.5. SPECIFICATION BINDING**

- a) All ILS Member Federations, Clubs and members and Compliant Boat Manufacturers shall accept this Specification, along with official amendments and relevant bulletins, as a condition of the boats use and manufacture. All clubs and competitors have a responsibility to ensure that their boats maintain compliance to the specifications.
- b) It shall be understood as a part of the condition of manufacture or use, that the ILS shall reserve the right to direct the removal of a core sample from the boat and submit that core for analysis and testing if, in the opinion of the ILS, there is reason to suspect that the GRP, foam or timber sandwich construction does not conform to the Specification.
- c) Should a dispute arise in relation to any aspect of this Specification ILS shall, after consultation with all the appropriate parties, shall make a final decision which shall be binding.

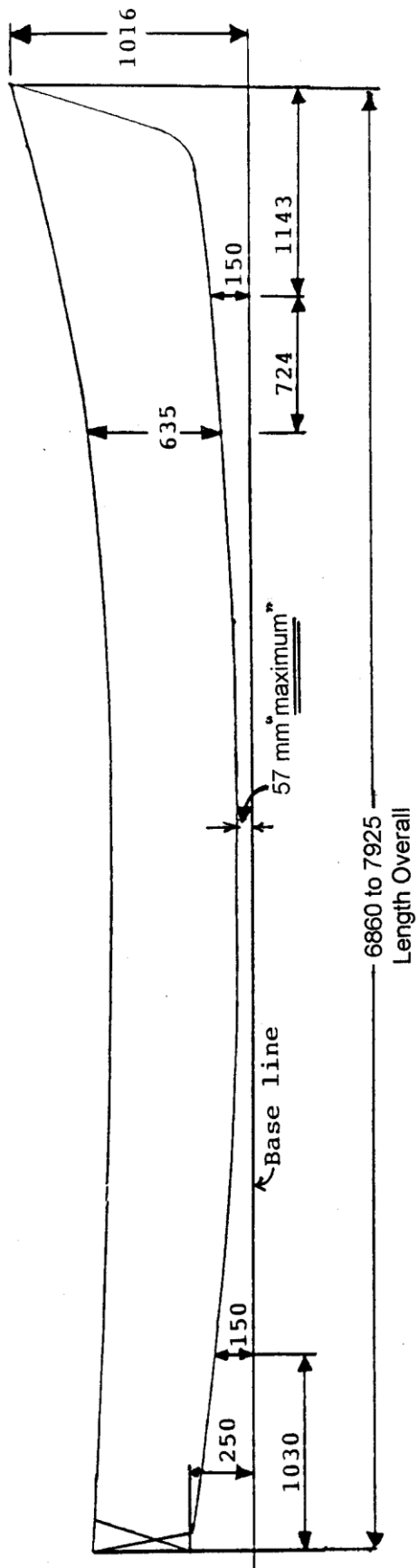

FIGURE 1. SURF BOAT MINIMUM ALLOWABLE PROFILE MEASUREMENTS (mm).

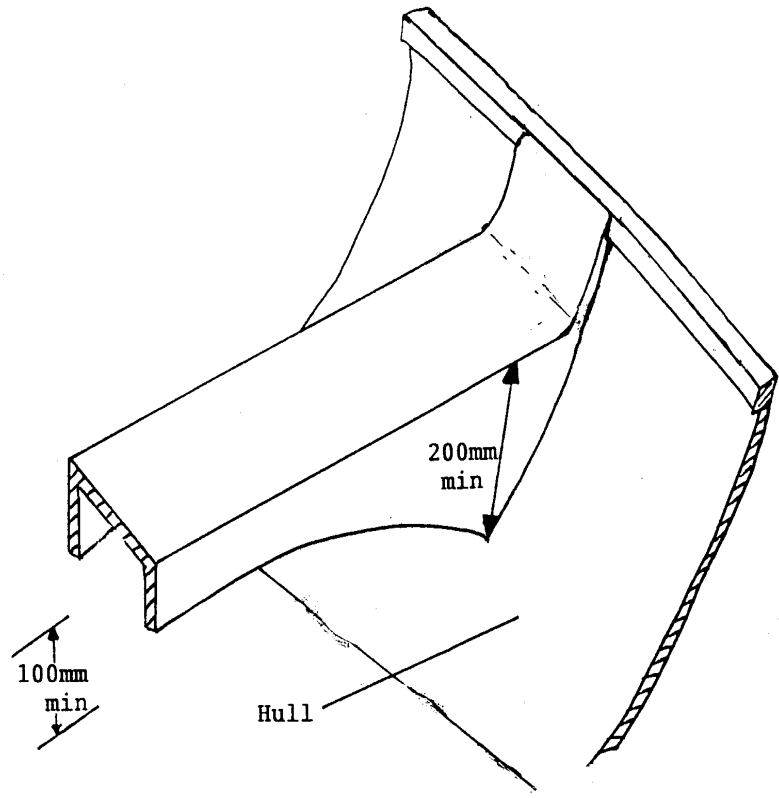

FIGURE 2. INVERTED U SHAPED THWART

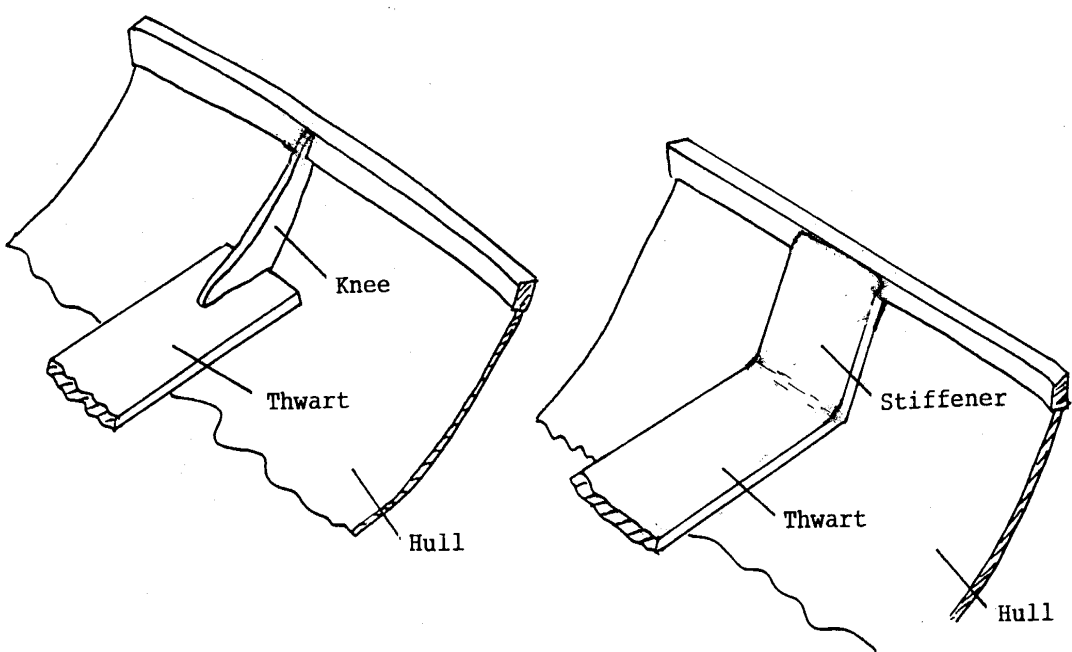

FIGURE 3. SINGLE THWART KNEE OR ALTERNATIVE STIFFENERS

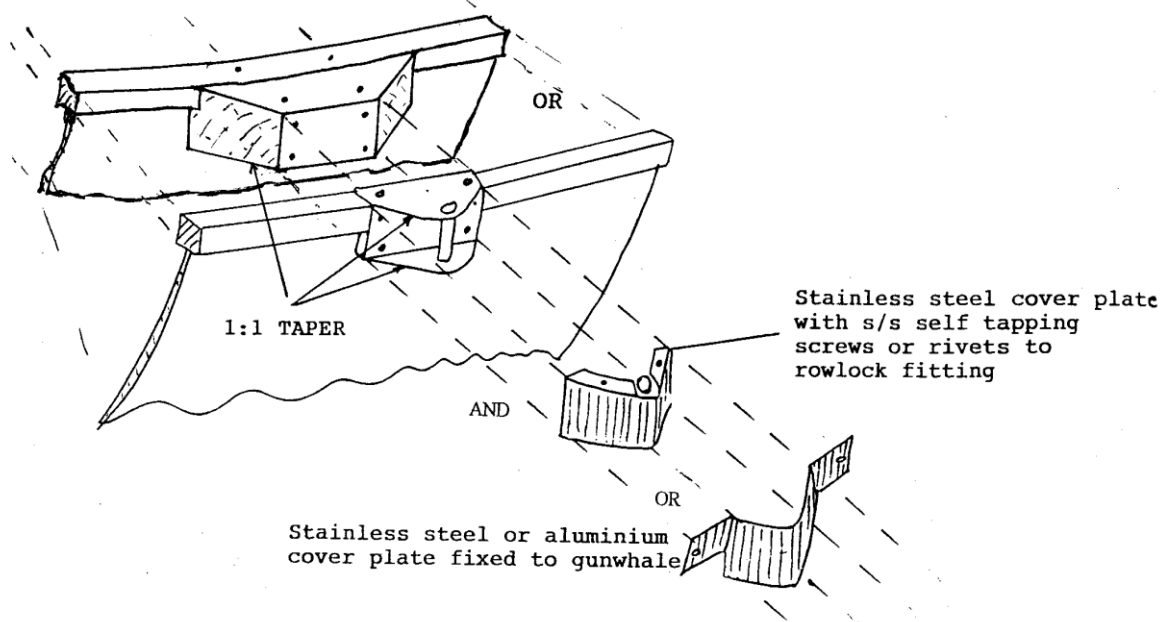
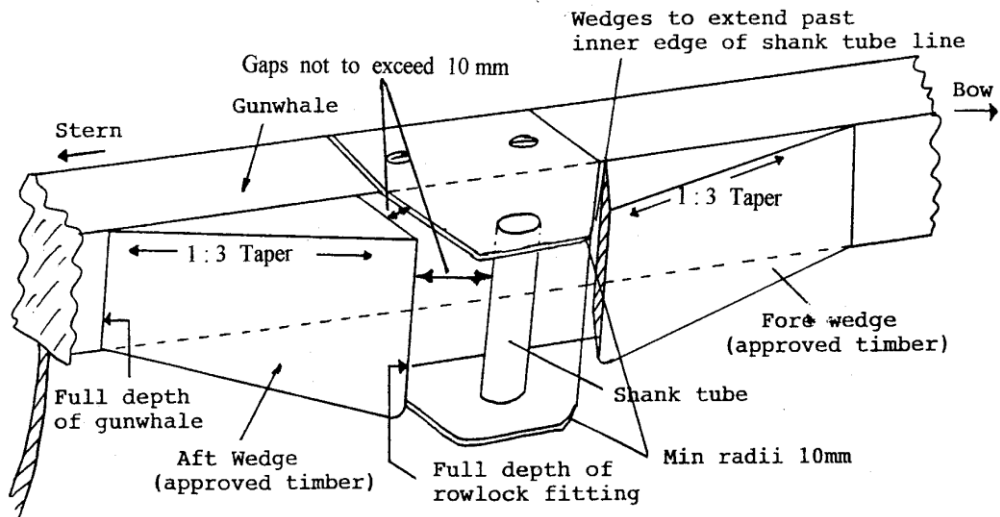
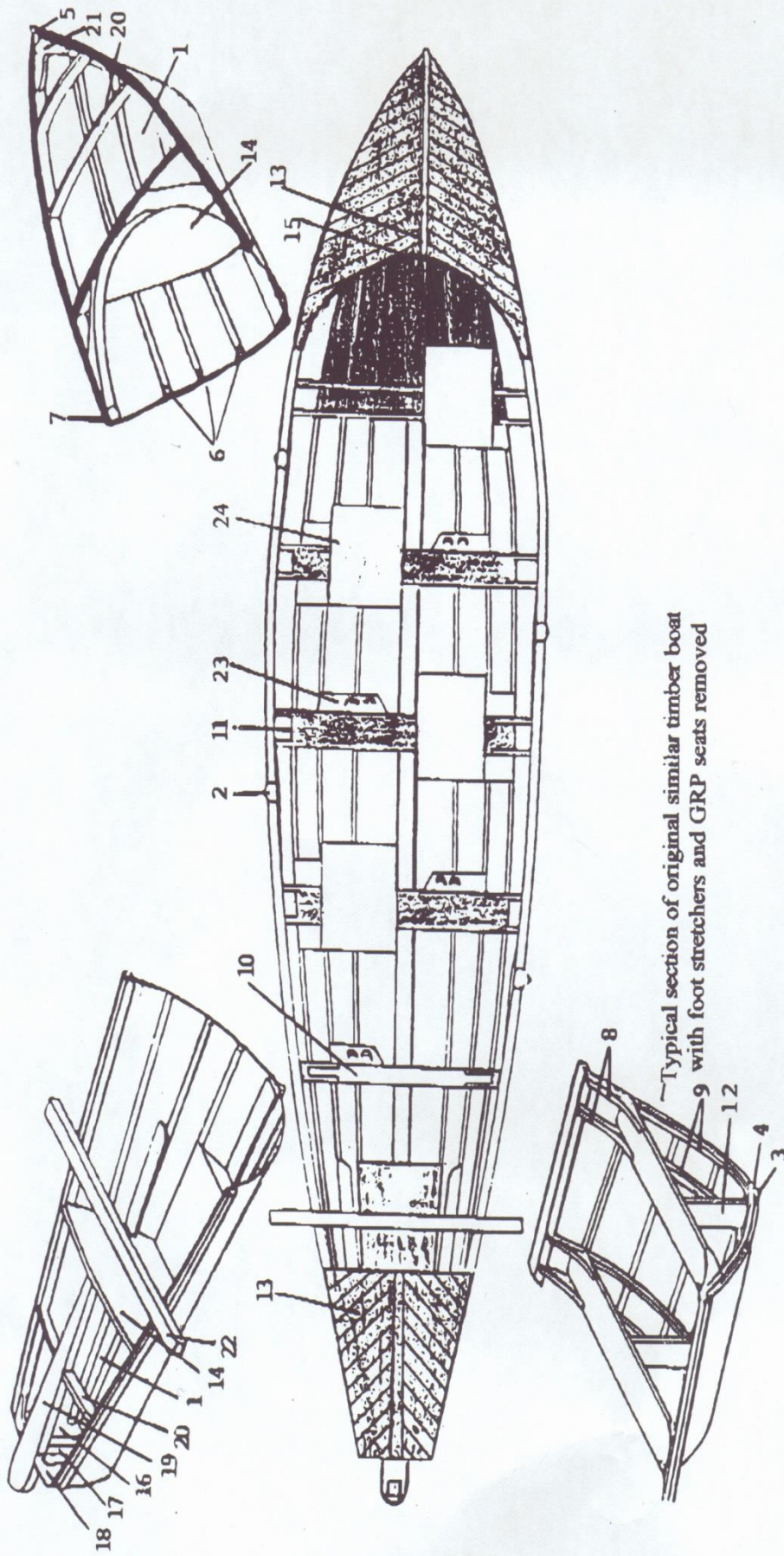

FIGURE 4. ROWLOCK FITTINGS APPROVED COVERS.



NOTE: Edges of wedges to be suitably rounded

FIGURE 5. ROWLOCK FITTINGS PROTECTIVE WEDGES.



**ITEM LIST**

1. Buoyancy	9. Timbers	17. Stern Post (Tuck Knees)
2. Rowlock Fittings	10. Extra Thwart	18. Quarter Knees
3. External False Keel	11. Thwarts	19. Sweep Outrigger
4. Inside Keel	12. Thwart Stanchion	20. Deck Beams
5. Stem	13. Decking	21. Breast Hook
6. Stringers (& Seat Riser)	14. Bulkheads	22. Quarter Bar
7. Gunwales	15. Coaming	23. Foot Stretchers
8. Thwart Knees	16. Tuck	24. GRP Seats

FIGURE 6. SECTIONS OF BOAT AND ITEM LIST